



Punch Genius
PG 1530



The Bend
The Combi
The Laser
The Press
 The Punch
The Shear
The System
The Software

The PUNCH

Versatile solutions for
servo-electric punching

Contents

- 03** Next level
- 04** Choosing an innovation leader
- 05** Green Means
- 06** Unbeatable tooling concept
- 09** Punch Sharp
- 12** Punch Sharp technical specifications
- 13** Punch Genius
- 17** Punch Genius technical specification
- 18** Around-the-clock production
- 20** Smart software
- 22** Prima Power Services
- 23** Contacts

Next level. **Integration.**

Today's volatile market demands that companies be competitive, accurate and reactive. Prima Power products continue to evolve, bringing efficiency to a whole new level. More productive machines, new automation solutions, and easy-to-use option suites are designed to meet the customer's real needs. To provide the best Prima Power technology, our team of experts will always be available to listen, assist and advise.

What can be found in this brochure

Fully servo-electric punching center for specified and multi-purpose productions.

Suite of options designed to achieve the best performance depending on the customer's needs.

Wide range of automation solutions to manage the whole production cycle.

Choosing an innovation leader



Prima Power is a leading specialist in machines and systems for sheet metal production. **Our offering in this field is one of the widest and covers all applications:** laser processing, punching, shearing, bending, automation and storages. The Group employs over 1,800 people and has manufacturing sites in Italy, Finland, China and the US, as well as a worldwide commercial and after-sales presence.

The Range

Thanks to the modularity of our products, we are able to offer manufacturing solutions ranging from single standalone machines up to the complete system for the management of work phases, flow of information and material handling. The integration with other technologies of sheet metal processing included in our product range, allows us to offer our customers the most complete production solutions possible.

THE BEND | Wide range of solutions for bending and automation.

THE COMBI | Integrated solutions for punching & laser cutting.

THE LASER | Laser machines and systems for 2D and 3D cutting, welding and drilling.

THE PRESS | Fast, accurate and efficient servo-electric press brakes.

THE PUNCH | State-of-the-art, versatile solutions for servo-electric punching.

THE SHEAR | Integrated systems for punching & shearing – highly productive with optimal sheet utilization.

THE SYSTEM | Full and modular range of solutions for the management of the whole working process.

THE SOFTWARE | Prima Power software solutions to maximize throughput.

Green Means

WHAT DOES GREEN MEAN?

Green means a win-win for you and sustainable development.

Sustainability adds to manufacturing efficiency and productivity.

Your customers, your employees and the community you operate in demand it more and more.

Sustainability & social responsibility are characteristics of a modern company and add to competitiveness. And you make better sheet metal components at lower cost.



Ultimate performance

The Genius series has models on two complementary performance levels.



PURE meets all the targets set for an attractively priced, yet efficient production machine.



DYNAMIC offers the best productivity and performance in the market.

Both models come with the latest features and can be equipped with the whole range of options.

The Sharp series has Dynamic available as optional.

Unbeatable tooling concept



LARGE TOOLING CAPACITY

The large number of tools with Prima Power punching machines results from a set of technical features which is not available from any other manufacturer:

- Two turret construction alternatives: 16 and 20 stations
- Multi-Tools®
- Rotating Auto-Index system
- Intelligent ram

Multi-Tool® is like a turret itself with separate tools in a cassette. Each tool can be selected with the rotating and locking mechanisms of the machine. The main Multi-Tool® types are:

- Fixed Multi-Tool® is installed in the factory to a standard tool holder. Depending on the manufacturer, a tool is selected by rotating the Multi-Tool® punch driver or the whole tool body.
- Fixed angle drop-in Multi-Tool® requires a D-size tool holder. Depending on the manufacturer, a tool is selected by rotating the Multi-Tool® punch driver or the whole tool body.
- Indexable drop-in Multi-Tool® requires a D-size tool holder and an optional mechanism to lock the punch driver. When locked, the tool is selected by rotating the Multi-Tool® body.
- Multi-Tools for Intelligent ram. These Multi-Tools can be fixed or indexable, depending on the Multi-Tool type.



BENEFITS

With carefully designed turret the Prima Power customer can make things happen easier and faster:

- with max. 400 tools in the turret, there is less need to stop the machine for re-tooling
- easier programming; a tool needed to make a part is in the turret
- better usage of the sheet as parts can be nested freely when the tools rotate.

CUSTOMIZED TURRET DESIGN

Tooling can be flexibly selected as required by the application. Up to 400 standard or 384 index tools can be simultaneously available in the turret for active use. Turrets with 16 and 20 stations are available in both Sharp and Genius series. The turrets are also compatible with Amada® tools.

The setup of all punching, forming and special tools is easy using the graphical tool library of the Tulus® operating system. Automatic tool lubrication system and vacuum assisted scrap removal are available as options.

An example turret layout

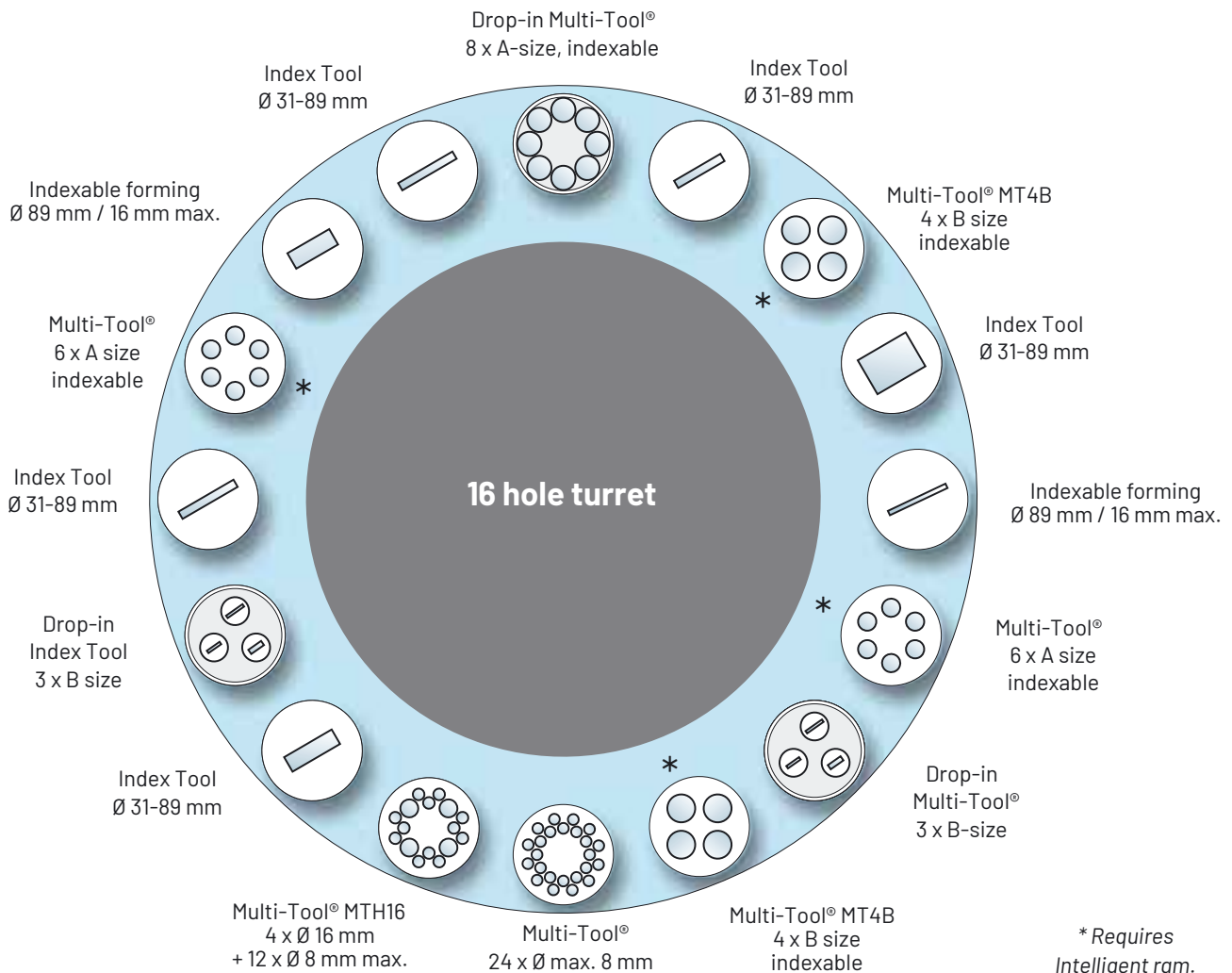



ACCESSIBLE

Prima Power punching machines are operated with a modern control unit and its touch screen panel. Management of machine setup and work queues is easy with the Tulus® user interface. The NC Express™ programming system and Tulus® work in perfect combination, provide comprehensive reports on machine and production status, and can be linked to the factory ERP system when required. Special attention has been paid to ergonomics and user friendliness of the control unit.

Manual loading and unloading is facilitated by a fixed or a movable table top. The movable table top can be locked in different positions. Thus even the smallest sheets can be handled close to the operator. The loading of heavy sheets is made easy with vertically moving sheet supports. Machine tables have been re-designed and equipped with more dense brushes, which together with the more solid table frame enable handling of sheets up to 250 kg. Clamp position is programmable for maximum sheet utilization and the position is changed automatically with the PCS function. Genius Series machines can be equipped with three clamps, which can be moved automatically and individually to a new position during program run to maximize sheet utilization without repositioning.

FORMING, TAPPING, MARKING - MORE VALUE TO PARTS

Prima Power's servo-electric Ecopunch® technology offers several highly productive tools in a single machine.

Watch the video on roll forming



Automatic tapping can be achieved with Multithread tapping tool.

Watch the video on Multithread tapping



Prima Power options include part tracing systems from labelling to laser marking.

Watch the video on laser marking



Punch Sharp™



ESSENTIAL FEATURES OF SERVO-ELECTRIC PUNCHING AT ENTRY LEVEL INVESTMENT

Prima Power Punch Sharp offers state-of-the-art in servo-electric punching technology, based on pioneering experience, in an eminently flexible and affordable package. The genius of servo-electric punching is how it combines energy saving and ergonomics with superb accuracy and productivity. Punch Sharp has been designed to offer versatile capacity made easy to utilize; machine control and user interface software with touch screen panel ensure fast setup and convenient operation.



NO TOOL SETUPS

Customized turret design allows up to 384 standard or 128 index tools for active use.



ACCESSIBLE

Easy to use and monitor.



COMPACT LAYOUT

Small floor space needed.



MODULAR TECHNOLOGY

Manufacturing cell can be equipped with automation solutions to achieve unattended production.



SCRATCH FREE

Vertically moving brushes prevent the scratching of sensitive materials.

OPTIONAL PERFORMANCE LEVEL



DYNAMIC

Dynamic performance 900 hpm/25 tons



MACHINE FEATURES, PUNCH SHARP™

Easy loading solutions

Lifting brushes for extra protection of sensitive material surfaces

Pneumatic central clamp locking system and Programmable Clamp Setting (PCS)

Accurate punching movement - excellent forming and marking capability

Lifting die - Excellent upforming capability



- With Pure Performance max. punching speed 700 hpm or max. punching force 23 tons.
With optional Dynamic Performance punching speed 900 hpm or max. punching force 25 tons.
- Fully programmable punching speed, upper and lower limit of stroke
- Tooling system compatible with the latest technologies, e.g.
indexable Multi-Tools® Touch screen and Tulus® user interface

Punch Sharp technical specifications

Approximate main dimensions without safety systems

Punch Sharp
 PS 1225: Y 6.0 m, X 8.0 m
 PS 1530: Y 6.6 m, X 8.1 m

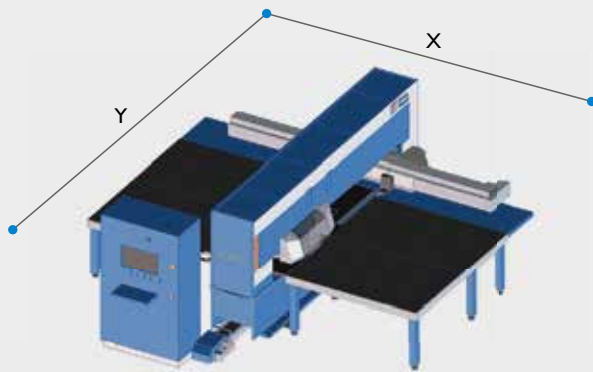

Punch Sharp with LST short
 PS 1225: Y 7.1 m, X 15.1 m
 PS 1530: Y 7.1 m, X 15.7 m

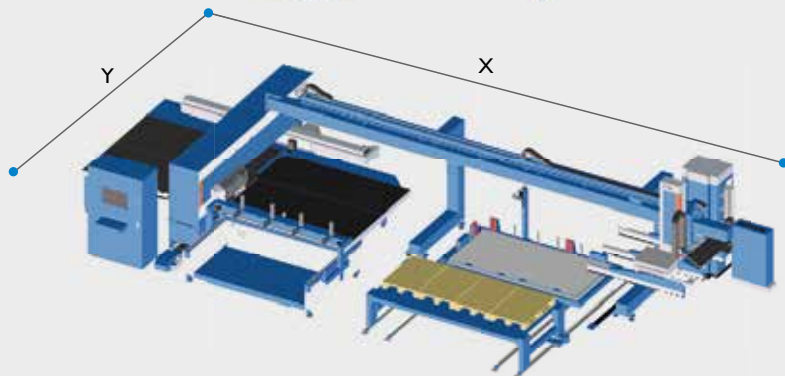

Punch Sharp with LST long
 PS 1225: Y 7.1 m, X 17.3 m
 PS 1530: Y 7.1 m, X 17.9 m

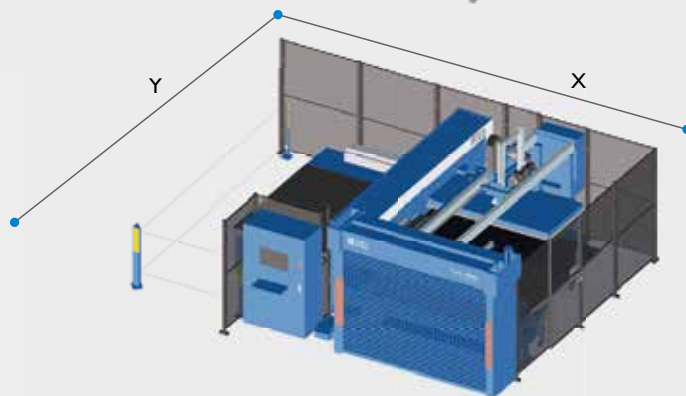

Punch Sharp with Compact Express
 PS 1225: Y 6.0 m, X 7.4 m
 PS 1530: Y 6.7 m, X 8.9 m

Model	Max. sheet size	X movement	Table height
Punch Sharp 1225 / 1530 / 1540	2,500 mm x 1,250 mm	2,500 mm	935 mm

	Punch Sharp 1225 / 1530 / 1540
Punching force	170, 200, 230 or 250 kN
Punching speed	up to 900 hpm
Punch stroke	Electrical servo motor
Max. tools in turret / index tools	16 hole turret: 384/384 20 hole turret: 400/240
Punch diameter, max.	89 mm
Material thickness, max.	8 mm
Sheet weight, max.	200 kg
Average power consumption	4 kW

Model	Sheet size X x Y, max.
Punch Sharp 1225	2,530 mm x 1,270 mm
Punch Sharp 1530	3,074 mm x 1,565 mm
Punch Sharp 1540	4,300 mm x 1,565 mm

WARNING!
 MOVING PART

Punch Genius™

Prima Power has gathered experience in the development of turret punch presses since the early 1980's, and while modern solutions are very different and the level much has, the targets have remained constant: always more ease of operation and higher productivity.

A modern turret punch press uses numerically controlled, servo-electric axes, which provides outstanding energy efficiency, low maintenance requirement and a high speed of operation. The cornerstones of its productivity include large tool capacity, the wide range of tools available and easy and fast setup change. Forming and other auxiliary work stages, and ease of use are further factors reducing the manufacturing cost per component thus making the turret punch press a productive and competitive manufacturing solution.



ACCESSIBLE

Easy to use and monitor



INTELLIGENT RAM

More tools in turret and shorter tool change times



SCRATCH FREE

Vertically moving brushes prevent the scratching of sensitive materials

TWO PERFORMANCE LEVELS



PURE

meets all the targets set for an attractively priced, yet efficient production machine



DYNAMIC

offers the best productivity and performance in the market



MACHINE FEATURES, PUNCH GENIUS™

23 ton and 30 ton punching force as standard, depending on selected performance.

20 station turret with 16 normal tool holders (A, B, C, D) and four index tool holders (2 x Bi, 1 x Ci, 1 x Di).
Max. 384 tools in the turret for active use. Turret is compatible with Amada® tools.

Two sheet clamps with central locking and foot pedal.

Optional third clamp available for better grip and support for larger sheets.



Prima Power CNC control: PC based TwinCat motion control with Rexroth IndraDrive motors & drives.

Touch screen operated graphical user interface; Tulus®, including one year maintenance licence.

Modular and easy to automate.



INTELLIGENT RAM

Intelligent ram is an option for Genius series punching to shorten tool change time and increase the number of tools in turret and especially that of index tools. Intelligent ram includes a rotating ram head, which enables old Multi-Tool® types to be used as indexable.

Up to 300 kN servo-electric punching force can be selected for the ram. Automatic overload protection and central lubrication ensure dependable machine operation.

Watch the video



SCRATCH FREE

A new feature is having moving brushes also in front and inside of the turret, which prevents effectively the scratching of sensitive materials. The movement is activated by the program when needed.

Further options include the servo-operated tapping unit TU6, automatic labelling device and Inkjet marking device.

The high-precision, servo-electric, indexable upforming cylinder provides 200 kN of forming power for fast making of even high and complicated forms and continuous roll forming.



Punch Genius technical specifications

Approximate main dimensions without safety systems

Punch Genius

PG 1225: Y 5.9 m, X 6.0 m
 PG 1530: Y 5.9 m, X 6.6 m
 PG 1540: Y 5.9 m, X 9.1 m

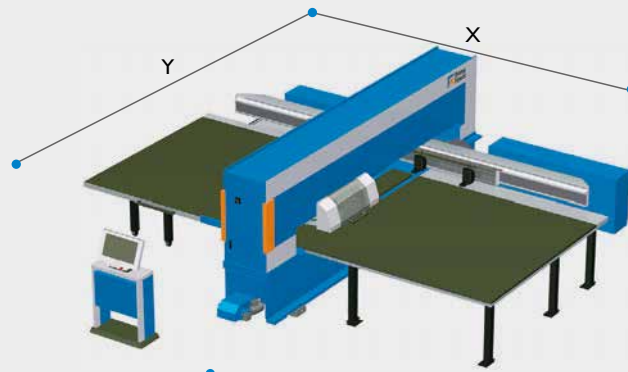

Punch Genius with LST short

PG 1225: Y 5.9 m, X1 13.6 m
 PG 1530: Y 6.4 m, X1 14.4 m

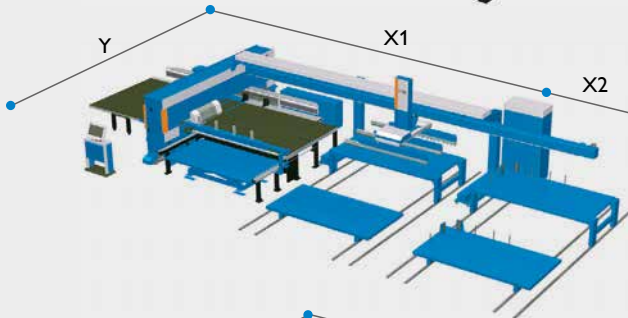

Punch Genius with LST long

PG 1225: Y 5.9 m, X2 16.0 m
 PG 1530: Y 6.4 m, X2 16.3 m

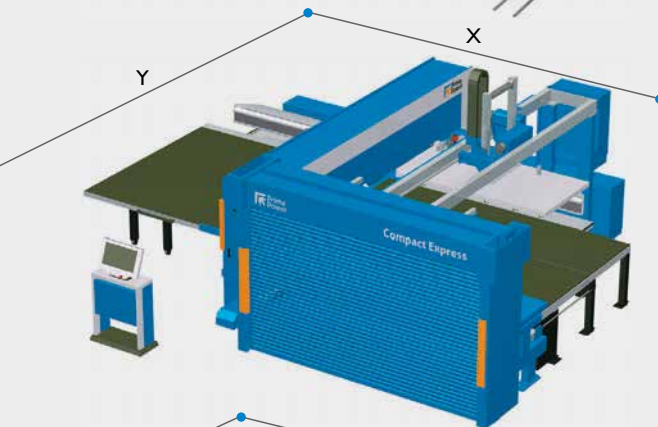

Punch Genius with Compact Express

PG 1225: Y 6.1 m, X 6.6 m
 PG 1530: Y 6.6 m, X 7.5 m

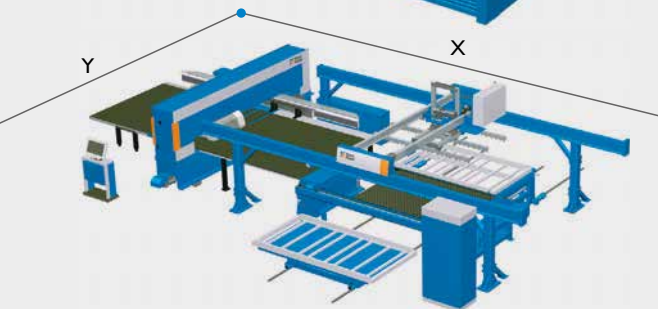

Punch Genius with LSR

PG 1530: Y 9.2 m, X 14.6 m
 PG 1540: Y 9.2 m, X 18.9 m

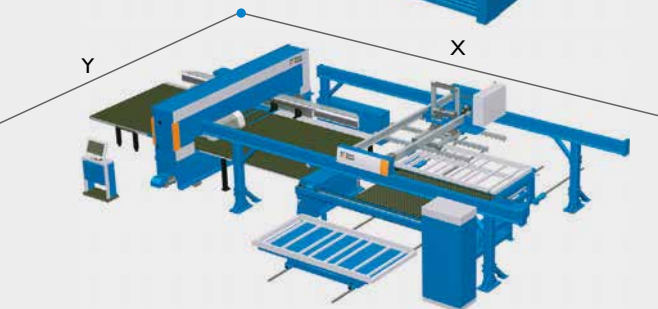

Punch Genius with LSR/2

PG 1530: Y 9.2 m, X 17.3 m
 PG 1540: Y 9.2 m, X 22.5 m

Model	Max. sheet size	X movement	Table height
PG1225	2,500 mm x 1,250 mm	2,500 mm	935 mm
PG1530	3,000 mm x 1,500 mm with repositioning	2,500 mm	935 mm
	3,000 mm x 1,500 mm	3,000 mm	935 mm
PG1540	4,300 mm x 1,500 mm with repositioning	3,000 mm	

Performance level	PG Pure	PG Dynamic
Punching force	170, 200 or 230 kN	300 kN
Punching speed	700 / min	1.000 / min
Punch stroke	Electrical servo motor	
Axis positioning speed	X25: 108; X30: 127 m/min	X25: 127; X30: 150 m/min
Max. tools in turret / index tools	16 station: 384/384, 20 station: 400/240	
Material thickness, max.	8 mm	
Sheet weight, max.	250 kg	
Average power consumption	4 kW	

Around-the-clock production

Prima Power machines are highly reliable and are used worldwide in the harshest production environments and for the most demanding manufacturing schedules.

This makes them particularly suitable for 24/7 operation.

COMPACT EXPRESS

Fully automated device for sheet loading and unloading

Sheet holder for scratch-free unloading

Machine can be operated with simultaneous manual and automated material handling

Sheets can be added and removed while the machine operates

Remote controlled safety door for easy material handling with a forklift

Compact size, does not increase required floor space much more from that of the machine

Two models for 2.5 m and 3 m sheets

UDC, UNLOADING DEVICE FOR SHEETS

Removes skeletons with micro-jointed parts from the machine table

Can be used with the machine or integrated to Compact Express

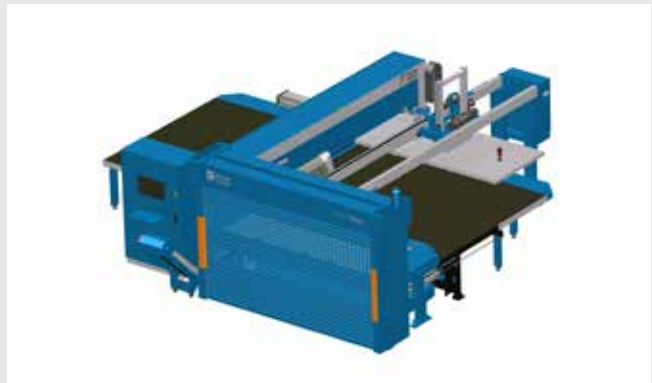

Punch Sharp with Compact Express

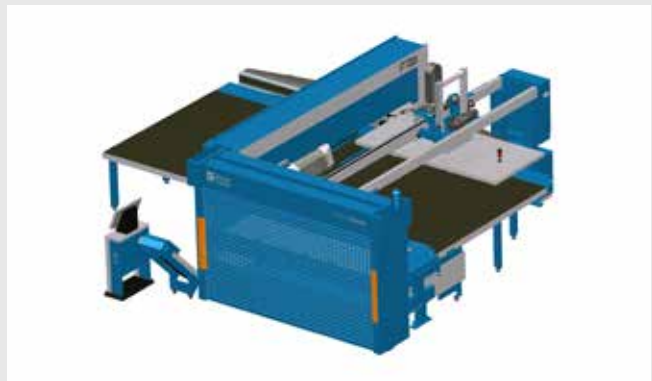

Punch Genius with Compact Express

PG 1225: Y 6.1 m, X 6.6 m

PG 1530: Y 6.6 m, X 7.5 m

LST, LOADING AND STACKING SYSTEM FOR AUTOMATED MATERIAL HANDLING

Compact high-performance automatic loading and stacking robot

LST loads the sheets into the machine, picks the parts and sorts them to stacks

Parts are picked up in front of the turret or from the cutting head by a pneumatic gripper

Skeletons are removed by the unloading device UDC integrated to machine table

Two main frame lengths with different number of table or wagon positions

Fully compatible with all our other automation systems

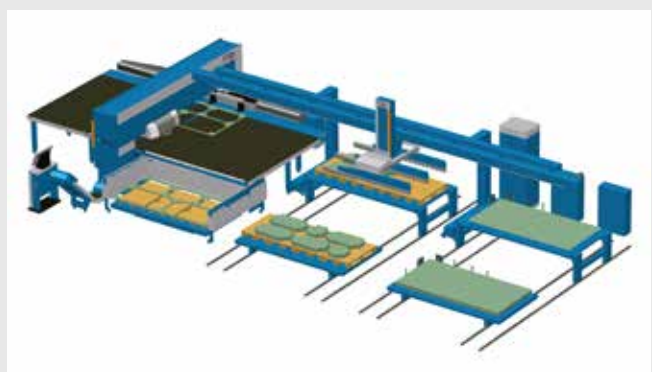

Punch Genius with LST short

PG 1225: Y 5.9 m, X1 13.6 m

PG 1530: Y 6.4 m, X1 14.4 m

Punch Genius with LST long

PG 1225: Y 5.9 m, X2 16.0 m

PG 1530: Y 6.4 m, X2 16.3 m

Note: Machine dimensions given here are without safety systems. Safetysystems depend on customer's factory layout and may increase required space.

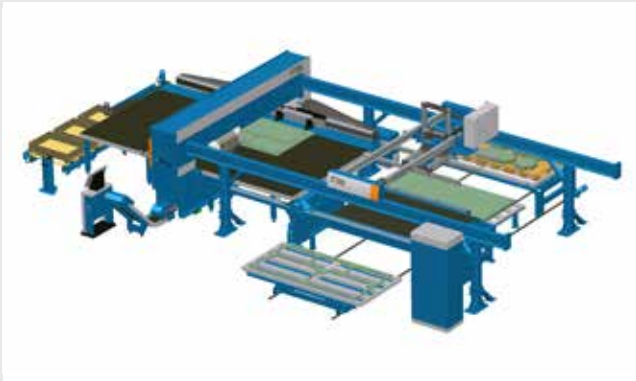

Punch Genius with LSR
 PG 1530: Y 9.2 m, X 14.6 m
 PG 1540: Y 9.2 m, X 18.5 m

LSR, LOADING AND STACKING ROBOT FOR AUTOMATIC MATERIAL LOADING AND PART SORTING

Loads sheets to the machine and stacks finished work pieces onto pallets. Due to the servo drive motion system the stacking is extremely accurate.

LSR is available in two sizes for 3.0 m and 4.3 m sheet lengths and two main frame lengths with different number of table or wagon positions.

SU, SORTING UNIT FOR SMALL COMPONENTS

A device that moves three EUR pallets to programmed positions under machine table

The unit is used to sort parts coming from the work chute of the machine directly on to pallets.

Perfect low-cost solution for automatic small part sorting

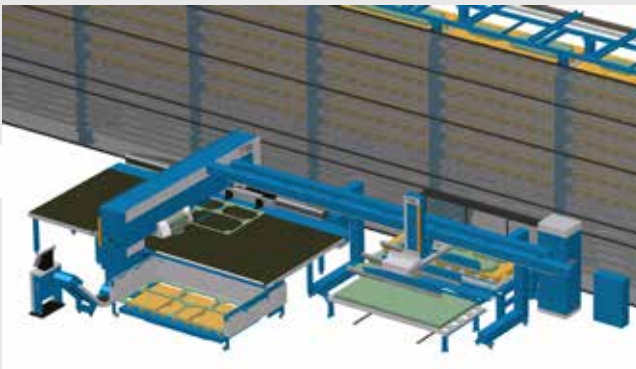

NIGHT TRAIN CONNECTION

With LST and/or LSR Punch Genius and Punch Sharp can be connected to flexible manufacturing system for continuous unmanned production

	SORT	UNLOAD	LOAD / UNLOAD	LOAD / STACK	LOAD / STACK	LOAD	FMS
	SU	UDC	COMPACT EXPRESS	LST	LSR	LD	NIGHT TRAIN CONNECTION
PUNCH SHARP 1225	•	•	•	•			•
PUNCH SHARP 1530	•	•	•	•			•
PUNCH SHARP 1540	•	•					
PUNCH GENIUS 1225	•	•	•	•			•
PUNCH GENIUS 1530	•	•	•	•	•	•	•
PUNCH GENIUS 1540	•	•			•	•	•

Smart software

The Prima Power software suite is a true ecosystem that provides the ideal solution to assist the customer in all phases of production, from offline programming to production data collection and reporting.

Prima Power software is developed for any customer use including off-line, on-board and mobile devices.



INDUSTRY 4.0

Focusing on connectivity and interaction between machines, people and processes, Prima Power is improving operational efficiency, connecting machines to a single platform, enabling seamless production information flow and maximizing machine performance.

To help our customers to fully capture the experience of Industry 4.0 and unleash the business potential of digital manufacturing, Prima Power has built a unique Industry 4.0 solution offering in three key areas: Smart Machines & Factories, Smart Software and Smart Remote Care.

OFFICE

PRODUCTION

MACHINE

Prima Power ERP connection

NC Express e3
- Offline programming

Tulus® Office Classic /Premium
- Offline programming
- Planning
- Reporting
- Production monitoring

Tulus® Terminal
- Production monitoring
- Product routing
- e-Kanban

Tulus® Office Basic
- Planning
- Production reporting

Tulus® Production Reporting / Tulus® Performance Reporting
- Reporting

Tulus® MUPS
- Production monitoring

Tulus®
NC Express e3

Prima Power's Tulus® and NC Express e3 software maximize throughput of manufacturing.

Tulus® Cell
- Planning
- HMI

Prima Power Services: key to better productivity

We believe in long-term relationships with our partners, and we think that the real product we deliver to our customer is not just the machine itself, but the production capacity that our customer can achieve with our products and technology. The heart of Prima Power service is the common goal we share with our customer: start, maintain and develop the plant's production capacity and maximize it.

Our Service covers the whole life cycle of the system and technology and contributes to reach one goal: maximize the productivity and the profit for our customers.



REMOTE CARE

A service for the remote diagnostics and assistance. Skilled service engineers are available to operate remotely with the customer's CNC.



FIELD SERVICE

In addition to preventive maintenance, we offer high-quality corrective maintenance to guarantee fast recovery when there is a problem. With more than 14,000 machines installed in more than 80 countries, we are able to give our customer the required assistance no matter where they are.



SERVICE AGREEMENTS

We continuously develop preventive maintenance plans for Prima Power machines. Maintenance visits are performed according to the task list specified for each machine type.



SPARE PARTS

Original Prima Power spare parts to guarantee full performance and prolonged durability.



CONSULTATION

Wide range of consultation services on machine operation, programming and maintenance.



UPDATES & UPGRADES

The modularity of the product range often allows upgrading of a machine or manufacturing system even years after the original delivery.

Contacts

Find your local Prima Power representative at primapower.com



primapower.com

